

GNSS RECEIVER WITH OPEN SOFTWARE INTERFACE (GOOSE)



GOOSE receiver platform

The GOOSE platform is an FPGA based GNSS receiver. It is therefore flexible in processing new or proprietary signals. It comprises 60 hardware channels in real time and provides an open software interface for customer applications. It grants deep access to the hardware interface, down to e.g. integrate and dump value levels. Additionally, the intermediate frequency signals can be recorded, processed and replayed with the platform. GOOSE is meant as a rapid prototyping solution for the development of state of the art GNSS receivers. The platform is dedicated to software developers and mobile communication operators. It is also characterized by four separate components: a multi-frequency GNSS antenna, an analog-frontend board, a baseband board, and the processor system.



GOOSE User Interface

Main benefits

- Flexible development platform with multi-system and multi-signal real-time processing
- Digital recording of intermediate frequency (IF) signals for SDR algorithm evaluation (post-processing)
- Analytic preprocessing of recorded IF-signals for replay
 - Insertion of Jamming and Spoofing
 - Mitigation of Jamming by Notch-Filter or Pulse-Blanker
- Digital Replay of IF-signals for easy and real-time repeatable tests
- Integrated antenna receiver combination (smart antenna)
- Guaranteed stable phase center for all GNSS frequencies
- Deployment in commercial PC or as an embedded platform
- Deep coupling and vector tracking in real time
- Extendable for meta signals
- Access to correlation values

Features

- 60 hardware channels
- Up to 25 Hz Raw data output (code, carrier, navigation data)
- Supported signals:
 - GPS (L1CA, L2C (M+L), L5)
 - Galileo (E1BC, E5a/E5b, E5 (AltBOC))
 - Optional SBAS (EGNOS)
 - GLONASS (G1, G2)
 - BeiDou (B1I, B2I)
- Open GNSS Receiver Protocol (OGRP), fully documented with parsing tool using CONVBIN from RTKLIB as RINEX converter
- C++-API to access the tracking I&D values and to close the tracking loops
- Logging of tracking I&D values

Fraunhofer Institute for Integrated Circuits IIS

Executive Director
Prof. Dr.-Ing. Albert Heuberger
Am Wolfsmantel 33
91058 Erlangen
Germany

Contact
Matthias Overbeck
Group Manager
Precise GNSS Receivers
Phone +49 (0) 9 11/5 80 61-6368
Fax +49 (0) 9 11/5 80 61-6398
matthias.overbeck@iis.fraunhofer.de

Nordostpark 84
90411 Nürnberg
Germany

www.iis.fraunhofer.de/positioning

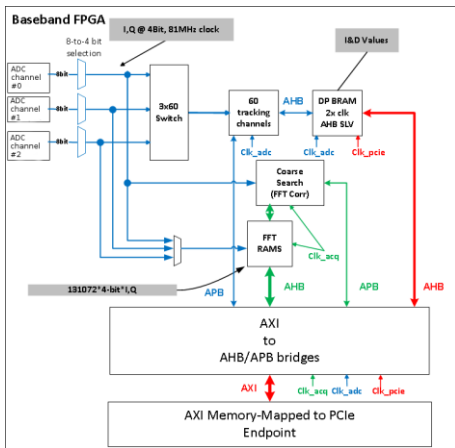

Baseband implementation scheme

- 10 MHz reference input
- 10 MHz reference output
- x PPS output (1 Hz - max. 25 Hz)
- 1 Ethernet port
- 2 full speed USB ports
- Digital recording and playback of front-end IF samples in real time

Performance

- 1 PPS out jitter: 12 ns
- 1 PPS out rise time: ~ 3 ns
- Cold start: 32 s, without startup time of SBC
- Warm start: 20 s, without startup time of SBC
- Re-acquisition: 1 - 2 s until satellite is again used in position solution
- Tracking: down to 30 dB-Hz
- Acquisition: from 32 dB-Hz (60% detection probability)

Technical Details

- Dimensions housing (HxWxD): 6,35 x 11,6 x 21,4 cm
- Dimensions electronic cube including antenna (HxWxD): 7 x 10 x 10 cm
- Weight electronic cube (incl. antenna): 350 g
- Weight electronic cube only: 220 g
- Weight housing: 1.1 kg
- Power: Input voltage: 6 - 36 V
- Power consumption embedded version: ~ 13 W
- Antenna LNA power output: output voltage 3.3 V, maximum current 100 mA
- Processor and OS:
 - PC version: any x86
 - Embedded version: Freescale i.MX 6 Dual Core ARM Cortex-A9
 - Ubuntu 16.4
- Connectors:
 - Antenna: SMA
 - REF IN: SMA
 - REF OUT: SMA
 - PPS OUT: Pin header
 - Power: 3.5''
 - COM1: Pin header
 - COM2: Pin header
 - 2x USB 2.0 Type A
 - Ethernet RJ45

GOOSE is distributed by TeleOrbit GmbH

The GOOSE platform has been developed within the framework of the GOOSE project (German acronym for »GNSS Receiver with open soft-ware interface«) by Fraunhofer Institute for Integrated Circuits IIS from 2014 to 2015 and has been extended for rail application in the Galileo-Online: GO! project from 2015 to 2018. Both supported by the German Federal Ministry for Economic Affairs and Energy. The GOOSE platform has been the positioning engine for autonomous truck driving in the PROPART project supported by GSA and is now further developed to high-sensitive forrest receiver for sub-meter under forrest canopy in the SuperNav project funded by the Federal Ministry for the Environment, Nature Conservation and Nuclear Safety.